

- (A) Part of BLOCK ASSY. 1.020
- (B) Part of GASKET SET (OVERHAUL) 1.060
- (D) Part of SEAL KIT 1.032
- (E) Part of PLUG KIT 1.038
- (F) Part of OIL PAN ASSY. 1.151
- (G) Part of GASKET SET 1.152
- (H) Part of ENGINE ASSY. 1.002

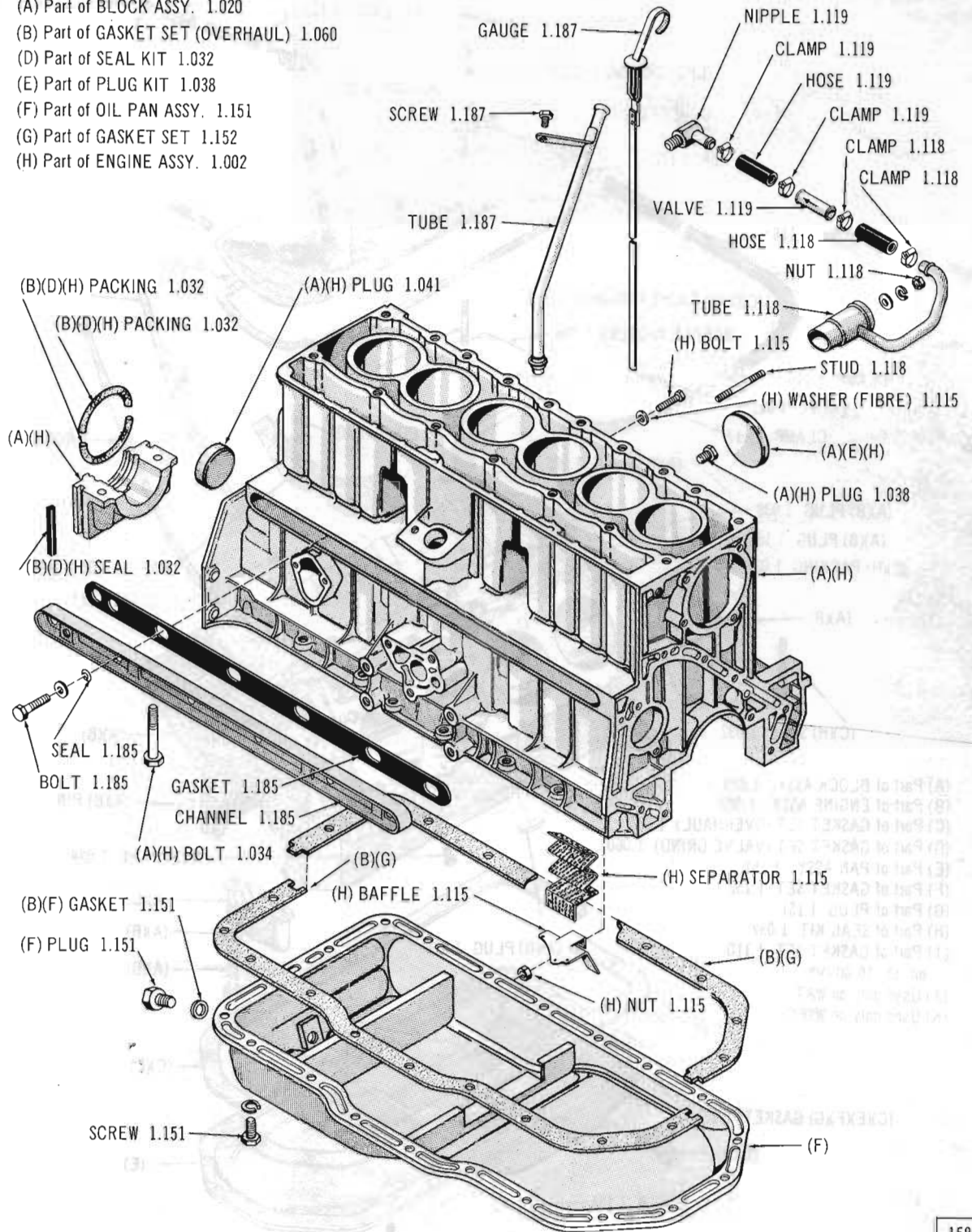

ENGINE CYLINDER BLOCK 61 thru 64 10 (OHVA)